

## Math 112: College Algebra

- Division:** Science, Mathematics, and Technology
- Credit Hours:** Three (3) credits
- Prerequisites:** Intermediate Algebra skills/ Math 095 or two years of high school algebra
- Textbook:** *Essentials of College Algebra*, Tenth Edition by Lial, Hornsby, and Schneider, Addison-Wesley (Pearson), 2011
- Course Description:** This course is designed to prepare students for the upper level college mathematics courses. Topics include graphs and transformations of functions, inverse and combinations of functions, solving linear and absolute value equations and inequalities, quadratic equations, polynomial equations, polynomial, rational, exponential, and logarithmic functions and their graphs.
- Required Materials for Instruction:** Textbook, as listed above.
- Calculator: a graphing calculator may only be used in classroom discussions. Its use is NOT permitted on any test or final. Scientific calculators are permitted.
- Course Syllabus (in the college store)
- Optional Materials:** InterAct Math Tutorial Web site: [www.interactmath.com](http://www.interactmath.com)  
Video Lectures on CD, available in BCC Libraries  
Student Solutions Manual  
MyMathLab Online Course (access code required)
- Attendance:** Attendance is taken at all class meetings. Please refer to the Burlington County College catalog for details of the college's policy and specifically your instructor for his/her policy.
- Course Content:** **Unit I** – Chapter 1: Equations and Inequalities
- Linear Equations
  - Complex Numbers
  - Quadratic Equations
  - Other Types of Equations and Applications
  - Inequalities
  - Absolute Value Equations and Inequalities

**Unit II – Chapter 2: Graphs and Functions**

- Rectangular Coordinates and Graphs
- Functions
- Linear Functions
- Equations of Lines; Curve Fitting
- Graphs of Basic Functions
- Graphing Techniques
- Function Operations and Composition

**Unit III – Chapter 3: Polynomial and Rational Functions**

- Quadratic Functions and Models
- Synthetic Division
- Zeros of Polynomial Functions
- Polynomial Functions: Graphs, Applications, and Models
- Rational Functions: Graphs, Applications, and Models

**Unit IV – Chapter 4: Inverse, Exponential, and Logarithmic Functions**

- Inverse Functions
- Exponential Functions
- Logarithmic Functions
- Evaluating Logarithms and the Change-of-Base Theorem
- Exponential and Logarithmic Equations

**Evaluation:**

There are **four (4) tests** – one each on Units I, II, III, and IV. Each test will be graded using the following scale:

<u>Percent Correct</u>	<u>Letter Grade</u>
100 - 90	A
89 - 80	B
79 - 70	C
69 - 60	D
below 60	F

The **final exam**, to be administered during exam week, is comprehensive and multiple-choice.

The **course grade** will be determined from the final test average. Adding the percent grades for each test, along with the score for the final exam, and dividing this sum by five will compute the final test average. The letter grades listed in the above scale will be used to determine the course grade.

Grades of “I” or “X” are assigned at the discretion of the instructor.

### Unit I: – Chapter 1: Equations and Inequalities

**Objectives:** Upon completion of this unit, the student should be able to define, explain, symbolize, and/or illustrate the following:

equation	solution	equivalent equations
identity	conditional equation	contradiction
linear equation in one variable $x$		
complex numbers	imaginary unit, $i$	standard form, $a + bi$
complex conjugates	quadratic equation in $x$	quadratic formula
completing the square		the discriminant
polynomial equations of higher degree		
equations involving radicals or rational exponents or absolute values		
solution set of an inequality		graph of an inequality
interval notation		linear inequalities
three-part inequalities		absolute value inequalities
solving quadratic inequalities		solving rational inequalities

Upon completion of this unit, the student should be able to:

1. Solve linear equations in one variable
2. Solve equations involving fractional expressions
3. Identify types of equations
4. Use the imaginary unit  $i$  to write complex numbers
5. Add, subtract, and multiply complex numbers
6. Use complex conjugates to write the quotient of two complex numbers in standard form
7. Simplify Powers of  $i$
8. Solve quadratic equations by factoring, extracting square roots, completing the square, and using the Quadratic Formula; use the Discriminant
9. Solve rational equations that lead to linear/quadratic equations
10. Solve equations involving radicals
11. Solve equations quadratic in form
12. Use properties of inequalities to solve linear inequalities
13. Solve three-part inequalities, quadratic inequalities, and rational inequalities
14. Solve absolute value equations and inequalities

### Unit II: – Chapter 2: Graphs and Functions

**Objectives:** Upon completion of this unit, the student should be able to define, explain, symbolize, and/or illustrate the following:

ordered pairs    rectangular coordinate system    distance formula  
 midpoint formula    graphing equations by point-plotting  
 parabola    relation    function    range/domain  
 input/output    independent variable    dependent variable  
 function notation    graph of a function    vertical line test  
 increasing, decreasing, and constant functions    slope  
 point-slope form    slope-intercept form  
 equations of vertical/horizontal lines    parallel/perpendicular lines  
 the identity, squaring, and cubing functions  
 the square root and cube root functions    absolute value functions  
 piecewise-defined function    even and odd functions  
 shifting, reflecting, and stretching graphs    translations  
 transformations on graphs    composition of functions  
 arithmetic operations on functions    the difference quotient  
 composition of functions and domain

Upon completion of this unit, the student should be able to:

1. Plot ordered pairs on the Rectangular Coordinate System
2. Use the Distance Formula to find the distance between two points
3. Use the Midpoint Formula to find the midpoint of a segment
4. Graph an Equation by Point Plotting
5. Decide whether relations between two variables represent a function
6. Find the domains and ranges of functions
7. Use the Vertical Line Test for functions
8. Use function notation and evaluate functions
9. Determine intervals on which functions are increasing, decreasing, or constant
10. Graph linear functions; find the slope of a line
11. Use Point-Slope form of an equation; use Slope-intercept form of an equation
12. Write equations of Vertical and Horizontal Lines
13. Write equations of Parallel and Perpendicular Lines
14. Recognize graphs of common functions
  - a. Identity function
  - b. Squaring function
  - c. Cubing function
  - d. Square Root function
  - e. Cube Root function
  - f. Absolute Value function
15. Graph Piecewise-Defined Functions
16. Use vertical and horizontal shifts and reflections to graph functions
17. Determine if functions are even, odd, or neither
18. Add, subtract, multiply, and divide functions
19. Find the Difference Quotient
20. Determine Composite Functions and their domains

### Unit III: – Chapter 3: Polynomial and Rational Functions

**Objectives:** Upon completion of this unit, the student should be able to define, explain, symbolize, and/or illustrate the following:

polynomial function of  $x$  with degree  $n$     quadratic function  
parabola    graphs of quadratic functions  
vertex, axis, domain, and range of parabola  
minimum and maximum values of quadratic functions  
Synthetic Division                                      Remainder Theorem  
Zeros of Polynomial Functions                      Factor Theorem  
Rational Zeros Theorem                              Number of Zeros Theorem  
multiplicity of the zero                              Conjugate Zeros Theorem  
Fundamental Theorem of Algebra                      Descartes' Rule of Signs  
Graph of a Polynomial Functions of degree 3 or more  
Turning Points and End Behavior                      Intermediate Value Theorem  
Graphs of Rational Functions                              Reciprocal Function  
Vertical and Horizontal Asymptotes                      Oblique asymptote

Upon completion of this unit, the student should be able to:

1. Use transformations to sketch graphs of polynomial functions
2. Graph Quadratic Functions by point plotting and by completing the square
3. Find the axis and the vertex of a parabola using the vertex formula
4. Find and use zeros of polynomial functions as sketching aids
5. Use synthetic division to divide polynomials by binomials of the form  $(x - k)$
6. Use the Remainder and Factor Theorems
7. Use the Rational Zeros Theorem to determine possible rational zeros of polynomial functions
8. Use the Fundamental Theorem of Algebra to determine the number of zeros of a polynomial function
9. Find all zeros of polynomial functions, including complex zeros
10. Find conjugate pairs of complex zeros
11. Find zeros of polynomials by factoring
12. Find horizontal and vertical asymptotes of graphs of rational functions
13. Sketch graphs of rational functions, as well as those having oblique asymptotes

---

### Unit IV: – Chapter 4: Inverse, Exponential, and Logarithmic Functions

**Objectives:** Upon completion of this unit, the student should be able to define, explain, symbolize, and/or illustrate the following:

One-To-One Function  
Inverse Functions  
natural base (base  $e$ )  
Logarithmic Equation  
properties of logarithms  
Common Logarithms  
Change-Of-Base Theorem  
Solving Logarithmic Equations

Horizontal Line Test  
Exponential Function  $f$  with base  $a$   
natural exponential function  
Logarithmic Function with base  $a$   
Theorem on Inverses  
Natural Logarithms  
Solving Exponential Equations

Upon completion of this unit, the student should be able to:

1. Determine whether a Function is One-To-One
2. Find Inverses of One-To-One Functions
3. Find the Equation of the Inverse of  $y = f(x)$
4. Graph a Function and its Inverse
5. Graph Exponential Functions
6. Evaluate exponential functions with base  $a$
7. Use Properties of Exponents to Solve Equations
8. Recognize and evaluate logarithmic functions with base  $a$
9. Graph Logarithmic Functions
10. Use properties of logarithms to evaluate or rewrite logarithmic expressions
11. Use properties of logarithms to expand or condense logarithmic expressions
12. Recognize Common and Natural Logarithms
13. Use the Change-Of-Base Theorem
14. Solve Exponential and Logarithmic Equations
15. Solve Base  $e$  Exponential and Logarithmic Equations

---

## Time Guideline

**NOTE:** For those students needing a review of basic algebra skills, it is strongly recommended that Chapter R be used for this purpose.

**Week # 1: Introduction** to the Course/**Chapter 1:** Functions and their Graphs

1. **Pre-test (score should be at least 14 correct out of 20, or 70%)**  
Recommended assignment: P. 81, 82 # 1-13, 16-29 all  
(prerequisites skills)
2. Section 1.1 – Linear Equations  
Recommended assignment: P. 88, 89 # 1-37 odd
3. Section 1.3 – Complex Numbers  
Recommended assignment: P. 109, 110 # 7-77 odd, 83-93 odd

- 
- Week # 2:**
1. Section 1.4 – Quadratic Equations  
Recommended assignment: P. 119, 120 # 1-12, 13-41 odd,  
# 45-63 odd, 73-79 all
  2. Section 1.6 – Other Types of Equations and Applications  
Recommended assignment: P. 142-144 # 1-25 odd, 35-51 odd,  
# 57-81 odd
- 

- Week #3:**
1. Section 1.7 - Inequalities  
Recommended assignment: P. 154-156 # 1-12, 13-33 odd,  
# 39-49 odd, 69-79 odd
  2. Section 1.8 – Absolute Value Equations and Inequalities  
Recommended assignment: P. 163, 164 # 1-8, 9-23 odd, 27-37 odd,  
# 43-59 odd
- 

- Week # 4:**
1. Review Unit I (Chapter 1)  
Recommended assignment: P. 170-177 # 1, 3, 19-43 odd, 50-53,  
# 63-95 odd, 111-123 odd;  
Chapter 1 Test: P. 177, 178 # 1-14, 16, 17, 24-30; **Practice Test #1**
  2. **TEST # 1 – Chapter 1**
  3. Unit II: Chapter 2, Section 2.1 – Rectangular Coordinates and Graphs  
Recommended assignment: P. 191-193 # 11-16, 31, 33, 43-54 all
- 

- Week #5:**
1. Section 2.3 – Functions  
Recommended assignment: P. 213-216 # 1-37 odd, 41-61 odd,  
# 77-82 all
  2. Section 2.4 – Linear Functions  
Recommended assignment: P. 225-227 # 1-28 all, 35-49 odd, 53-64
  3. Section 2.5 – Equations of Lines; Curve Fitting  
Recommended assignment: P. 242-244 # 5-25 odd, 31-39 odd,  
# 47-53 odd
-

- Week # 6:**
1. Section 2.6 – Graphs of Basic Functions  
Recommended assignment: P. 255, 256 # 1-10 all, 17-31 odd
  2. Section 2.7 – Graphing Techniques  
Recommended assignment: P. 270, 271 # 1-13 odd, 31-36 all,  
# 37-57 odd
- 

- Week # 7:**
1. Section 2.8 – Function Operations and Composition  
Recommended assignment: P. 282-285 # 1-13 odd, 23-29 odd,  
# 33-47 odd, 57-63 odd
  2. Review Unit II (Chapter 2):  
Recommended assignment: P. 292-296 # 1-6, 21-31 odd, 35-57 odd,  
# 63-73 odd, 77, 79, 101-123 odd;  
Chapter 2 Test: P. 297-299 # 1-6, 9-22; **Practice Test # 2**
  3. **TEST # 2 – Chapter 2**
- 

- Week # 8:**
1. Unit III - Chapter 3: 3.1 – Quadratic Functions and Models  
Recommended assignment: P. 311-313 # 1-12, 13-25 odd
  2. Section 3.2 – Synthetic Division  
Recommended assignment: P. 326, 327 # 1-47 odd
  3. Section 3.3 - Zeros of Polynomial Functions  
Recommended assignment: P. 337, 338 # 1-39 odd, 43-47 odd, 55, 57
- 

- Week # 9:**
1. Section 3.4 – Polynomial Functions: Graphs, Applications, and Models  
Recommended assignment: P. 351, 352 # 1-8, 9-17 odd, 21-31 odd,  
#47, 49, 51
  2. Section 3.5 - Rational Functions: Graphs, Applications, and Models  
Recommended assignment: P. 371-375 # 1-6, 9-16, 29-36, 37-45 odd,  
# 53-67 odd
-

- Week # 10:** 1. Review Unit III (Chapter 3):  
Recommended assignment: P. 393-396 # 1, 3, 17-27 odd, 35, 37,  
# 53-58, 71, 73, 75  
Chapter 3 Test: P. 398, 399 # 1-15, 18-20; **Practice Test # 3**
2. **TEST # 3 - Chapter 3**
- 

- Week # 11:** 1. Unit IV - Chapter 4: Section 4.1 – Inverse Functions  
Recommended assignment: P. 411-413 # 3-15, 35-45 odd, 55, 57
2. Section 4.2 – Exponential Functions  
Recommended assignment: P. 427-429 # 1-15 odd, 25-39 odd,  
# 49-67 odd
- 

- Week # 12:** 1. Section 4.3 - Logarithmic Functions  
Recommended assignment: P. 441-444 # 1-9 odd, 13-29 odd, 33,  
# 37, 59-77 odd, 81-87 odd
2. Section 4.4 – Evaluating Logarithms and the Change-Of-Base Theorem  
Recommended assignment: P. 453 # 11-17 odd  
P. 457 # 61-71 odd
- 

- Week # 13:** 1. Section 4.5 - Exponential and Logarithmic Equations  
Recommended assignment: P. 464, 465 # 1-49 odd
2. Review Unit IV (Chapter 4)  
Recommended assignment: P. 487, 488 # 1-8, 17-19, 22-24,  
# 37-57 odd  
Chapter 4 Test: P. 490-492 # 1-16; **Practice Test # 4**
- 

- Week # 14:** 1. **TEST # 4 - Chapter 4**
2. Final Exam Review in Syllabus and review all Practice Tests # 1-4
- 

**Week # 15: FINAL EXAM (comprehensive)**

---

Mth 112: Practice Test 1 (Unit I)

SHORT ANSWER. Write the word or phrase that best completes each statement or answers the question.

**Solve the equation.**

1)  $-2x + 4 + 5(x + 1) = -(4x - 4)$

1) \_\_\_\_\_

2)  $1 - \frac{9}{6x} = \frac{2}{5}$

2) \_\_\_\_\_

**Decide whether the equation is an identity, a conditional equation, or a contradiction. Give the solution set.**

3)  $12(x - 3) = 2(6x - 2) - 32$

3) \_\_\_\_\_

**Find the sum or difference. Write the answer in standard form.**

4)  $(4 + 6i) - (-7 + i)$

4) \_\_\_\_\_

**Find the product. Write the answer in standard form.**

5)  $(8 + 5i)^2$

5) \_\_\_\_\_

6)  $(9 - 4i)(2 + 9i)$

6) \_\_\_\_\_

**Multiply or divide, as indicated. Simplify the answer.**

7)  $\frac{\sqrt{-12} \cdot \sqrt{-3}}{\sqrt{4}}$

7) \_\_\_\_\_

**Simplify the power of i.**

8)  $i^{51}$

8) \_\_\_\_\_

**Find the quotient. Write the answer in standard form.**

9)  $\frac{7 - 3i}{5 - 3i}$

9) \_\_\_\_\_

**Solve each equation.**

10)  $7x^2 + 4x - 3 = 0$

10) \_\_\_\_\_

11)  $x^2 = 8$

11) \_\_\_\_\_

**Solve each equation.**

12)  $x^3 + 64 = 0$

12) \_\_\_\_\_

$$13) \frac{5}{x+7} + \frac{11}{x-2} = \frac{9}{x^2 + 5x - 14}$$

13) \_\_\_\_\_

$$14) \frac{6}{x+5} = 1 - \frac{1}{x-5}$$

14) \_\_\_\_\_

$$15) \sqrt{2x+15} - x = 6$$

15) \_\_\_\_\_

$$16) \sqrt{3x+1} = 3 + \sqrt{x-4}$$

16) \_\_\_\_\_

$$17) \sqrt[3]{4+6x} - \sqrt[3]{1-8x} = 0$$

17) \_\_\_\_\_

$$18) (4x-2)^2 - 4(4x-2) + 3 = 0$$

18) \_\_\_\_\_

$$19) (x+3)^{2/3} + 2(x+3)^{1/3} - 15 = 0$$

19) \_\_\_\_\_

$$20) |7x+1| + 4 = 7$$

20) \_\_\_\_\_

$$21) |-6+3x| = |1-4x|$$

21) \_\_\_\_\_

**Solve each inequality. Give answer in interval notation.**

$$22) 38 > 5x + 3 \geq 18$$

22) \_\_\_\_\_

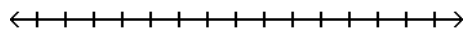

$$23) x^2 + 7x \leq -12$$

23) \_\_\_\_\_

$$24) \frac{x-7}{x+8} \leq 0$$

24) \_\_\_\_\_

$$25) |8x-8| - 8 \geq -1$$

25) \_\_\_\_\_

$$26) 3 + \left| 1 - \frac{1}{2}x \right| \geq 5$$

26) \_\_\_\_\_

**Use the discriminant to determine the number of distinct solutions and whether they are rational, irrational, or nonreal complex.**

$$27) 3y^2 = 6y - 6$$

27) \_\_\_\_\_

SHORT ANSWER. Write the word or phrase that best completes each statement or answers the question.

**Find the distance between points P and Q.**

1)  $P(-5, -1), Q(5, 4)$

1) \_\_\_\_\_

**Find the coordinates of the other endpoint of the segment, given its midpoint and one endpoint.**

2) midpoint  $(2, 6)$ , endpoint  $(-1, 1)$

2) \_\_\_\_\_

**Graph the equation by plotting points.**

3)  $y = -x^2 + 1$

3) \_\_\_\_\_

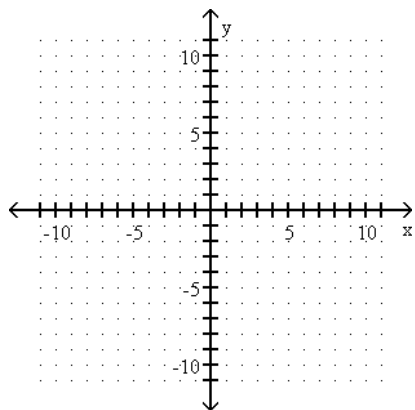

**Decide whether the relation defines a function.**

4)  $\{(-2, 1), (-3, -6), (3, -4), (3, 6)\}$

4) \_\_\_\_\_

5)  $y = x^3$

5) \_\_\_\_\_

**Give the domain and range of the relation.**

6)  $y = \sqrt{2 + x}$

6) \_\_\_\_\_

7)  $y = \frac{6}{9 - x}$

7) \_\_\_\_\_

**Find the slope of the line satisfying the given conditions.**

8) through  $(5, -9)$  and  $(-4, -2)$

8) \_\_\_\_\_

**Write an equation for the line described. Give your answer in slope-intercept form.**

9)  $m = -\frac{3}{5}$ , through  $(7, 6)$

9) \_\_\_\_\_

Determine the intervals over which the function is decreasing, increasing, and constant.

10)

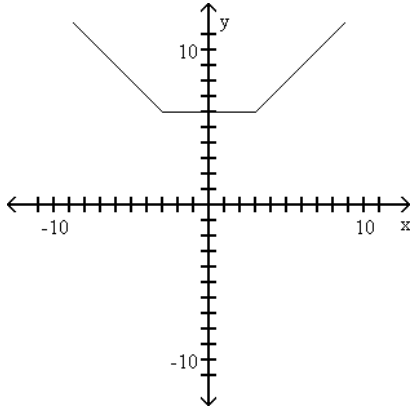

10) \_\_\_\_\_

Graph the linear function and give the domain and the range. If the function is a constant function, identify it as such.

11)  $h(x) = 2$

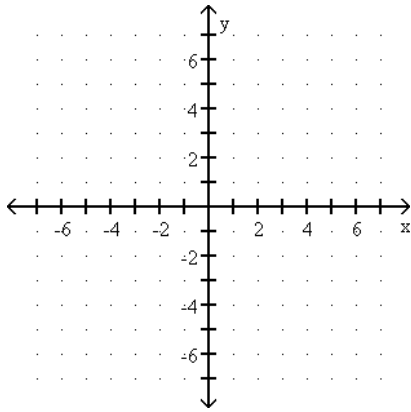

11) \_\_\_\_\_

12)  $f(x) = \frac{1}{2}x - 4$

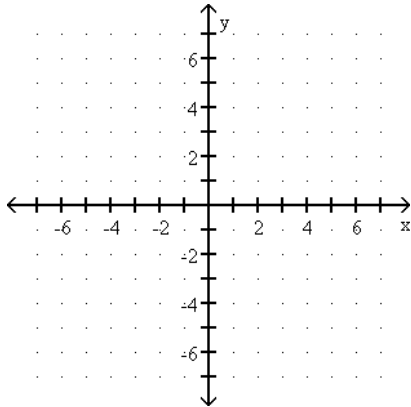

12) \_\_\_\_\_

Find the slope and the y-intercept of the line.

13)  $3x - 5y = -5$

13) \_\_\_\_\_

**Find the slope of the line and sketch the graph.**

14)  $2x - 3y = -5$

14) \_\_\_\_\_

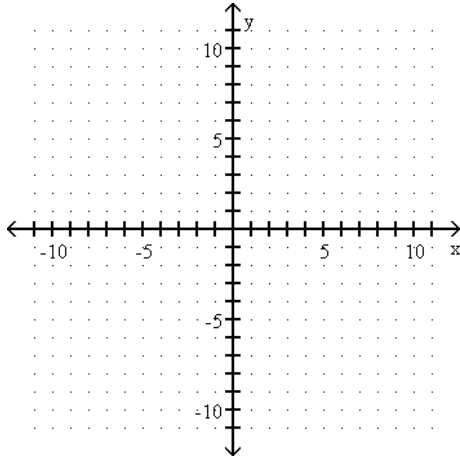

**Write an equation for the line described. Write the equation in the form specified.**

15) parallel to  $y + 6x = 4$ , through  $(3, 4)$ ; slope-intercept form

15) \_\_\_\_\_

16) perpendicular to  $7x - 9y = -35$ , through  $(4, -7)$ ; standard form

16) \_\_\_\_\_

**Find the requested value.**

17)  $f(7)$  for  $f(x) = \begin{cases} 2x + 1, & \text{if } x < 1 \\ 7x, & \text{if } 1 \leq x \leq 9 \\ 7 - 9x, & \text{if } x > 9 \end{cases}$

17) \_\_\_\_\_

**Describe how the graph of the equation relates to the graph of  $y = x^2$ .**

18)  $f(x) = (x - 8)^2 + 5$

18) \_\_\_\_\_

**Determine if the function is even, odd, or neither.**

19)  $f(x) = -6x^3 + 5x$

19) \_\_\_\_\_

20)  $f(x) = 5x^4 + 5x - 2$

20) \_\_\_\_\_

**For the pair of functions, find the indicated sum, difference, product, or quotient.**

21)  $f(x) = 9x - 4$ ,  $g(x) = 7x - 9$

Find  $(f - g)(x)$ .

21) \_\_\_\_\_

22)  $f(x) = 3x - 4$ ,  $g(x) = 7x + 3$

Find  $(fg)(x)$ .

22) \_\_\_\_\_

Compute and simplify the difference quotient  $\frac{f(x+h) - f(x)}{h}$ ,  $h \neq 0$ .

23)  $f(x) = 8x - 15$

23) \_\_\_\_\_

Graph the functions.

24)  $f(x) = \begin{cases} 2x + 9, & \text{if } x < 0 \\ 2x^2 - 1 & \text{if } x \geq 0 \end{cases}$

24) \_\_\_\_\_

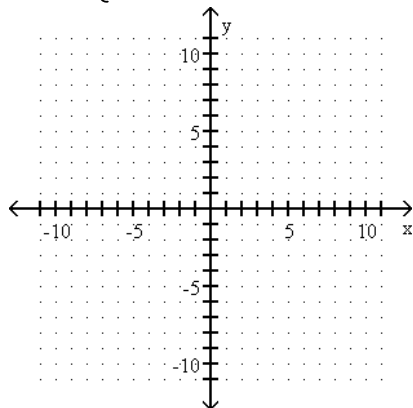

25)  $h(x) = \sqrt{-x+1} - 2$

25) \_\_\_\_\_

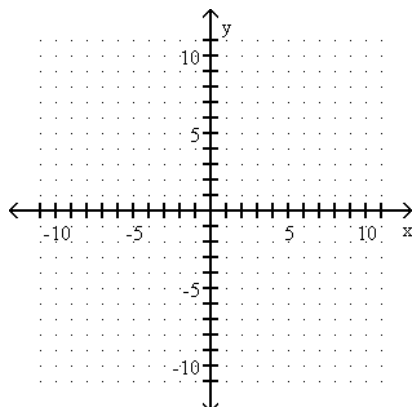

For the given functions  $f$  and  $g$ , find the indicated composition.

26)  $f(x) = -4x + 9$ ,  $g(x) = 2x + 7$

26) \_\_\_\_\_

$(g \circ f)(x)$

Find the requested function value.

27) Find  $(f \circ g)(3)$  when  $f(x) = 7x - 6$  and  $g(x) = 5x^2 - 7x - 6$ .

27) \_\_\_\_\_

Mth 112: Practice Test 3 (Unit III)

SHORT ANSWER. Write the word or phrase that best completes each statement or answers the question.

**Find the domain and range of the function.**

1)  $f(x) = (x + 2)^2 + 7$

1) \_\_\_\_\_

**Identify the vertex of the parabola.**

2)  $f(x) = (x - 6)^2 - 1$

2) \_\_\_\_\_

3)  $y = -2x^2 + 8x - 8$

3) \_\_\_\_\_

**Sketch the graph of the parabola.**

4)  $y = -\frac{1}{2}(x - 2)^2 - 3$

4) \_\_\_\_\_

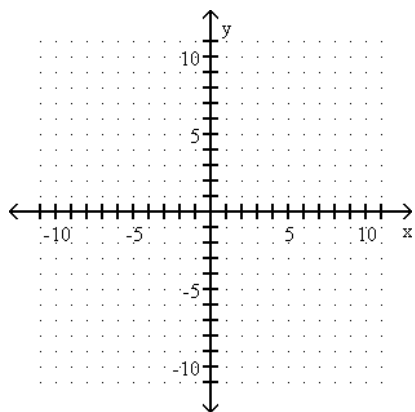

5)  $y = 3x^2 + 2x - 2$

5) \_\_\_\_\_

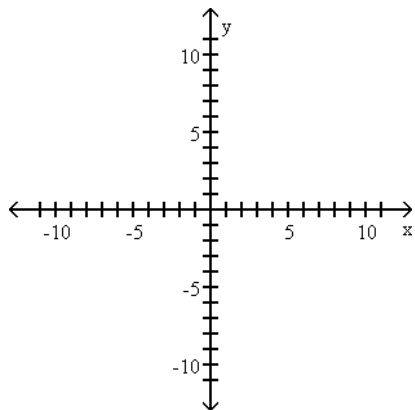

**Solve the problem.**

6) The number of mosquitoes  $M(x)$ , in millions, in a certain area depends on the June rainfall  $x$ , in inches:  $M(x) = 19x - x^2$ . What rainfall produces the maximum number of mosquitoes?

6) \_\_\_\_\_

Use synthetic division to perform the division.

$$7) \frac{-5x^3 - 33x^2 - 12x + 36}{x + 6}$$

7) \_\_\_\_\_

Use the remainder theorem and synthetic division to find f(k).

$$8) k = -3; f(x) = 2x^3 - 5x^2 - 4x + 17$$

8) \_\_\_\_\_

Use synthetic division to decide whether the given number k is a zero of the given polynomial function.

$$9) -1; f(x) = -2x^3 + 6x^2 + x - 7$$

9) \_\_\_\_\_

$$10) 7i; f(x) = x^3 + 2x^2 + 49x + 98$$

10) \_\_\_\_\_

Use the factor theorem to decide whether or not the second polynomial is a factor of the first.

$$11) x^3 - 7x^2 + 15x - 25; x - 5$$

11) \_\_\_\_\_

Factor f(x) into linear factors given that k is a zero of f(x).

$$12) f(x) = x^3 - 3x^2 - 25x + 75; k = 5$$

12) \_\_\_\_\_

$$13) f(x) = x^3 - 27x - 54; k = -3 \text{ (multiplicity 2)}$$

13) \_\_\_\_\_

For the polynomial, one zero is given. Find all others.

$$14) P(x) = x^3 - 3x^2 - 5x + 39; -3$$

14) \_\_\_\_\_

Give all possible rational zeros for the following polynomial.

$$15) P(x) = 2x^3 + 8x^2 + 5x - 8$$

15) \_\_\_\_\_

Find the zeros of the polynomial function and state the multiplicity of each.

$$16) f(x) = -5x^2(x - 9)(x + 4)^3$$

16) \_\_\_\_\_

$$17) f(x) = (x^2 + x - 12)^5(x - 1 + \sqrt{7})^3$$

17) \_\_\_\_\_

Find a polynomial of lowest degree with only real coefficients and having the given zeros.

$$18) 5 + 2i \text{ and } 5 - 2i$$

18) \_\_\_\_\_

Find the correct end behavior diagram for the given polynomial function.

$$19) P(x) = -6x^3 + 3x^2 + 8x - 2$$

19) \_\_\_\_\_

**Solve the problem.**

20) The graph of  $f(x) = x^3 + 4x^2 - x - 4$  is shown below. Use the graph to factor  $f(x)$ . 20) \_\_\_\_\_

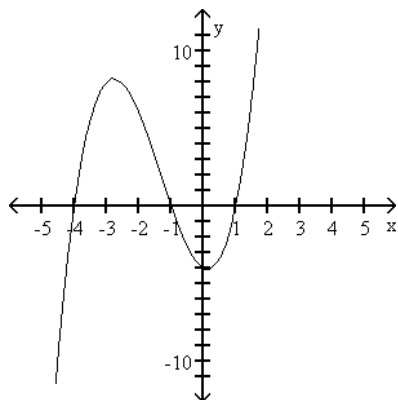

**Use the intermediate value theorem for polynomials to show that the polynomial function has a real zero between the numbers given.**

21)  $f(x) = 5x^3 + 2x^2 + 6x + 1$ ; -1 and 0 21) \_\_\_\_\_

**Find any vertical asymptotes.**

22)  $f(x) = \frac{5x + 9}{2x - 1}$  22) \_\_\_\_\_

23)  $f(x) = \frac{x - 6}{x^2 - 4}$  23) \_\_\_\_\_

**Find the horizontal asymptote of the given function.**

24)  $g(x) = \frac{x^2 + 8x - 5}{x - 5}$  24) \_\_\_\_\_

25)  $h(x) = \frac{4 - 9x}{-3x + 7}$  25) \_\_\_\_\_

**Give the equation of the oblique asymptote, if any.**

26)  $f(x) = \frac{x^2 + 2x - 3}{x - 4}$  26) \_\_\_\_\_

Sketch the graph of the rational function.

$$27) f(x) = \frac{x - 2}{x + 3}$$

27) \_\_\_\_\_

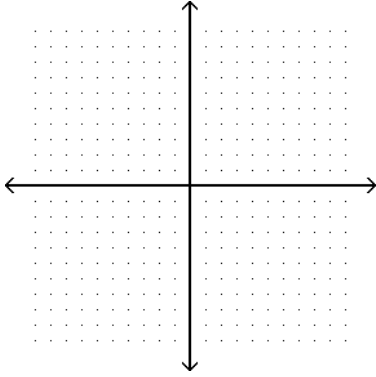

$$28) f(x) = \frac{x^2 + 6x - 7}{x^2 - x - 20}$$

28) \_\_\_\_\_

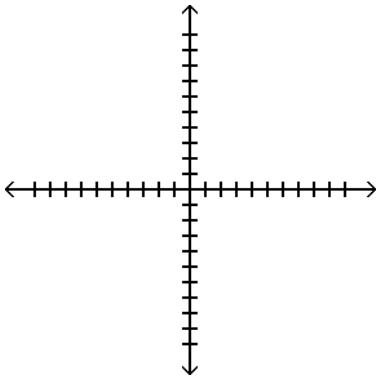

Mth 112: Practice Test 4 (Unit IV)

SHORT ANSWER. Write the word or phrase that best completes each statement or answers the question.

**Determine whether or not the function is one-to-one.**

1)  $f(x) = x^2 + 7$

1) \_\_\_\_\_

2)  $f(x) = 2x^3 - 7$

2) \_\_\_\_\_

**Decide whether or not the functions are inverses of each other.**

3)

3) \_\_\_\_\_

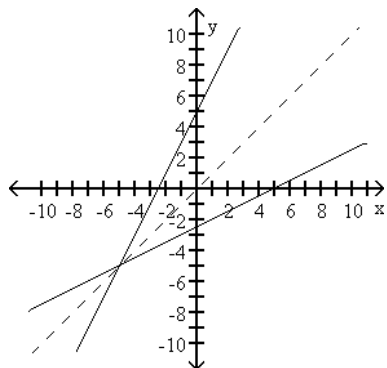

**If f is one-to-one, find an equation for its inverse.**

4)  $f(x) = 7x - 4$

4) \_\_\_\_\_

5)  $f(x) = \frac{9}{x + 8}$

5) \_\_\_\_\_

**Find the function value.**

6) Let  $f(x) = 5^x$ . Find  $f(-3)$ .

6) \_\_\_\_\_

**Graph the function.**

7)  $f(x) = 4^x$

7) \_\_\_\_\_

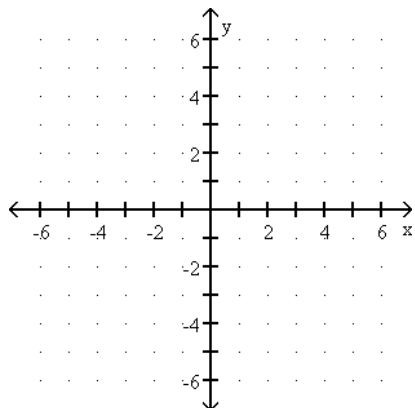

**Evaluate the logarithm.**

8)  $\log_8 \frac{1}{64}$

8) \_\_\_\_\_

9)  $\log_5 (-1)$

9) \_\_\_\_\_

**Write in logarithmic form.**

10)  $4^2 = 16$

10) \_\_\_\_\_

**Write an equivalent expression in exponential form.**

11)  $\log_{10} 0.01 = -2$

11) \_\_\_\_\_

**Solve the equations.**

12)  $3^{(8 - 2x)} = 81$

12) \_\_\_\_\_

13)  $\left(\frac{8}{7}\right)^x = \frac{343}{512}$

13) \_\_\_\_\_

14)  $e^{5x} - 1 = (e^4)^{-x}$

14) \_\_\_\_\_

15)  $x = 6^{\log_6 13}$

15) \_\_\_\_\_

16)  $\log_7 \sqrt{76} = x$

16) \_\_\_\_\_

17)  $\log(5 + x) - \log(x - 2) = \log 2$

17) \_\_\_\_\_

18)  $\ln(4x - 5) + \ln(x - 3) = \ln 15$

18) \_\_\_\_\_

19)  $\log_5(x + 2) + \log_5(x - 2) = 3$

19) \_\_\_\_\_

**Solve the equation. If necessary, round to the nearest thousandth.**

20)  $2^{(x - 1)} = 17$

20) \_\_\_\_\_

21)  $2e^{4x - 3} = 8$

21) \_\_\_\_\_

**Use the product, quotient, and power rules of logarithms to rewrite the expression as a single logarithm.**

**Assume that all variables represent positive real numbers.**

22)  $(\log_a q - \log_a r) + 6 \log_a p$

22) \_\_\_\_\_

Given  $\log_{10} 2 = 0.3010$  and  $\log_{10} 3 = 0.4771$ , find the logarithm without using a calculator.

23)  $\log_{10} 72$

23) \_\_\_\_\_

Write the expression as a sum, difference, or product of logarithms. Assume that all variables represent positive real numbers.

24)  $\log_4 \left( \frac{\sqrt{5}}{6} \right)$

24) \_\_\_\_\_

25)  $\log_a(8x^5y)$

25) \_\_\_\_\_

Use the change of base rule to find the logarithm to four decimal places.

26)  $\log_{5.1} 295$

26) \_\_\_\_\_

Graph the function. Give the domain and range.

27)  $f(x) = \log_3 x$

27) \_\_\_\_\_

